

Stock program Type 70E



Advantages:

- Very few wear parts over the whole drilling range
- New chip breakers for high feed rates and high productivity
- No adjustment after exchanging indexable inserts
- We keep wear parts in stock
- Newly designed tool shape for optimum cooling lubricant flow
- Reinforced drill head body in the area of the peripheral insert
- Maximum protection of guide pads against damage due to enhanced embedding
- Highly wear-resistant drill head body

Stock program features:

- Solid drill heads now available as new stock program.
- Ex stock (subject to prior sale).
- Type 70 stock drill heads do not include inserts and guide pads – please order separately.

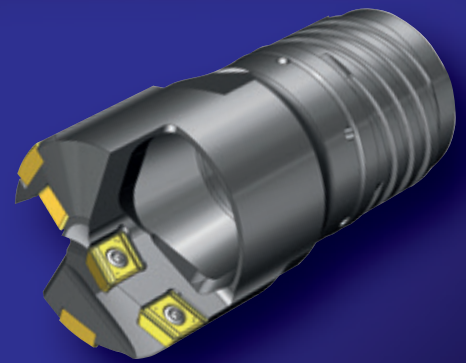

Drilling range
25.00 - 65.00 mm

Stock program:

Order No.	Part No.	DC	OAL	PL	DCON	LCON
70E04-2550-110	501007197	25.50	74	2.0	21.0	21.5
70E06-3010-110	501007196	30.10	74	2.2	25.5	24.5
70E07-3200-110	501002996	32.00	74	2.4	28.0	24.5
70E07-3260-110	501006586	32.60	74	2.4	28.0	24.5
70E09-3820-110	501007212	38.20	89	3.1	33.0	30.5
70E09-3910-110	501006548	39.10	89	3.2	33.0	30.5
70E10-4000-110	501003232	40.00	89	3.1	36.0	30.5

The above dimensions apply to a completely assembled tool

Inserts and guide pads not included – please order separately

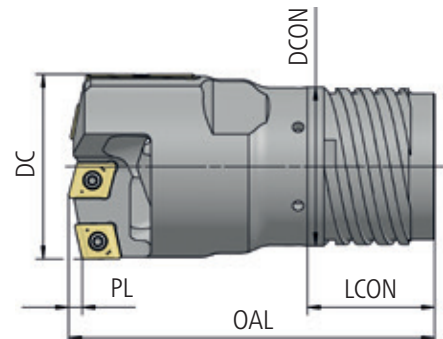

botek
Präzisionsbohrtechnik GmbH

Längenfeldstraße 4 · 72585 Riederich · Germany
P +49 7123 3808-0 · E-Mail Info@botek.de
www.botek.de