

# Stock program Type 70A



### Advantages:

- Very few wear parts over the whole drilling range
- New chip breakers for high feed rates and high productivity
- No adjustment after exchanging indexable inserts
- We keep wear parts in stock
- Newly designed tool shape for optimum cooling lubricant flow
- Reinforced drill head body in the area of the peripheral insert
- Maximum protection of guide pads against damage due to enhanced embedding
- Highly wear-resistant drill head body

### Stock program features:

- Solid drill heads now available as new stock program.
- Ex stock (subject to prior sale).
- Type 70 stock drill heads do not include inserts and guide pads – please order separately.



**Drilling range**  
**25.00 - 65.00 mm**

### Stock program:

Order No.	Part No.	DC	OAL	PL	DCON
70A04-2500-110	501001689	25.00	74	2.1	19.5
70A04-2600-110	501002372	26.00	74	2.1	19.5
70A05-2800-110	501002369	28.00	74	1.9	21.0
70A06-3000-110	501002366	30.00	74	2.2	23.5
70A07-3200-110	501001912	32.00	74	2.4	25.5
70A08-3500-110	501002374	35.00	82	3.1	28.0
70A09-3800-110	501002375	38.00	89	3.1	30.0
70A11-4500-110	501002380	45.00	94	3.5	36.0

The above dimensions apply to a completely assembled tool

**Inserts and guide pads not included – please order separately**

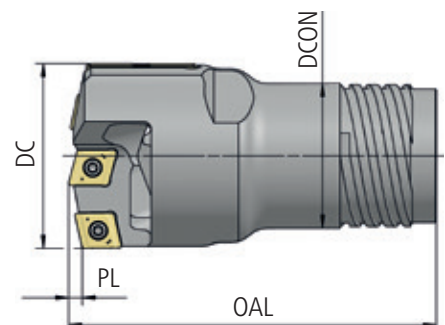

**botek**  
**Präzisionsbohrtechnik GmbH**

Längenfeldstraße 4 · 72585 Riederich · Germany  
P +49 7123 3808-0 · E-Mail [Info@botek.de](mailto:Info@botek.de)  
[www.botek.de](http://www.botek.de)